

BASES

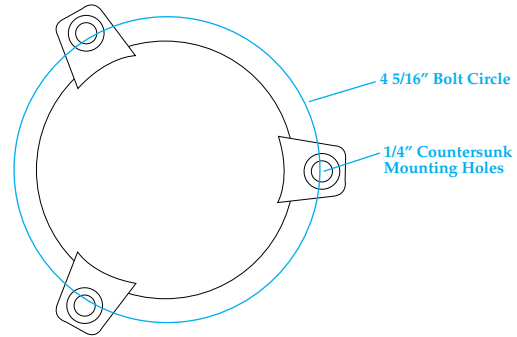

STANDARD BASE

Model 300 – Holds all 300 series PanaVise heads and Circuit Board Holders. The patented single load control knob and exclusive split-ball feature firmly lock the head into place. Loosening the knob reduces the load on the split ball, permitting the head to be removed from the base. This exclusive feature allows use of numerous heads with one base. By acquiring different heads, a versatile work holding system can be created. This base has three 1/4" countersunk mounting holes on a 4 5/16" bolt circle for attaching directly to a work bench or to a portable Base Mount (see page 14). It is 3 3/4" (9.5cm) high, weighs 1 lb. 7 oz. (0.7kg) and accepts all 5/8" (1.6cm) stems. **Model 300-45** allows the vise head to move 45° on both sides of the vertical plane.



Base Foot Pattern for Model 300 and Model 305



LOW-PROFILE BASE

Model 305 – This base has all the tilt, turn and rotate control features of the Standard Base, but it's only 2 1/2" (6.4cm) high. Designed for working close to the bench surface, it features three 1/4" countersunk mounting holes on a 4 5/16" bolt circle for attaching directly to a work bench or to a portable Base Mount (see page 14). When used with the 304 Low Profile Head (see page 12), it allows the work to be swung out and away from the bench surface. Weighs 1 lb. 5 oz. (0.6kg) and accepts all 5/8" stems (1.6cm). **Model 305-45** allows the vise head to move 45° on both sides of the vertical plane.



UP/DOWN CONVERTER BASE

Model 336 Up/Down Converter Base (for use with 325 Base Mount)

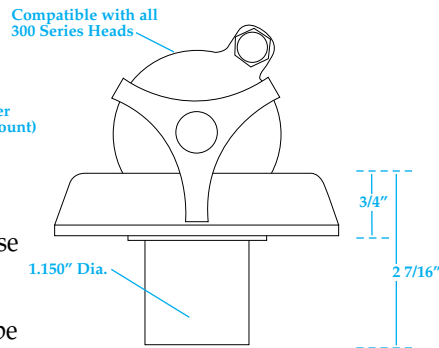

Model 336 – The 336 Up/Down Converter Base has all the tilt, turn and rotate of the original PanaVise base and may be fitted with all heads and Circuit Board Holders. It is specifically designed for use with the 325 Up/Down Positioners, adding the dimension of variable height to your work area. Weight is 1 lb. 1 oz. (0.5kg) and overall height is 3 1/2" (8.9cm).



VACUUM BASE

Model 380 – Our Vacuum Base is in wide use for portable applications. Simply flip the lever to "activate" the rubber base and attach the unit to any smooth, non-porous surface. Won't mar or scratch, and easily detaches when the lever is moved. Moistening the pad with water will increase its grip. Holds all regular PanaVise Heads, Circuit Board Holders, and 5/8" (1.6cm) stems with all the "tilt, turn and rotate" of the other bases. Weight is 1 lb. 11 oz. (0.8kg); height is 3 1/4" (8.3cm).

